

DELineator 5000 LSS

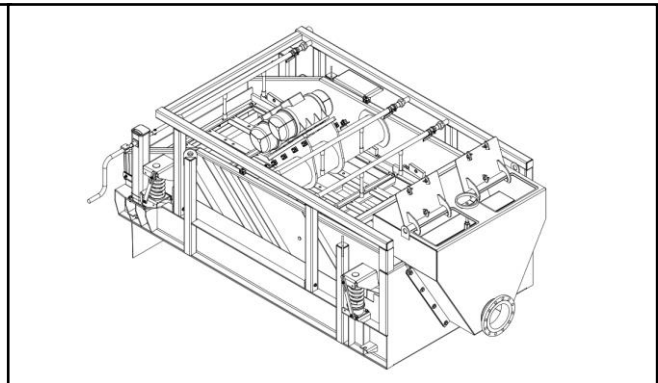
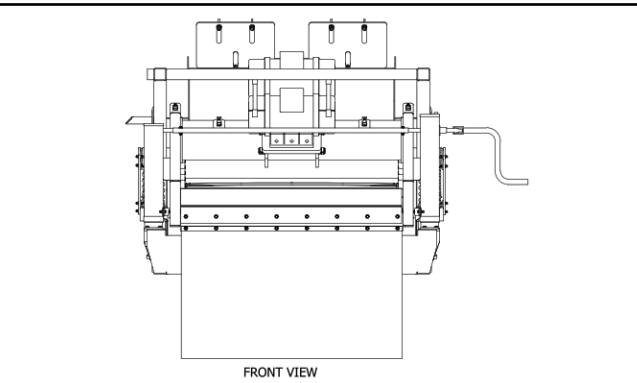
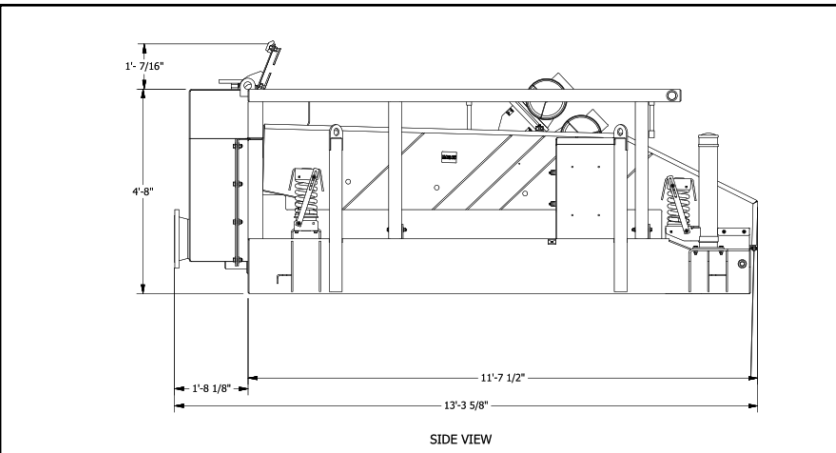
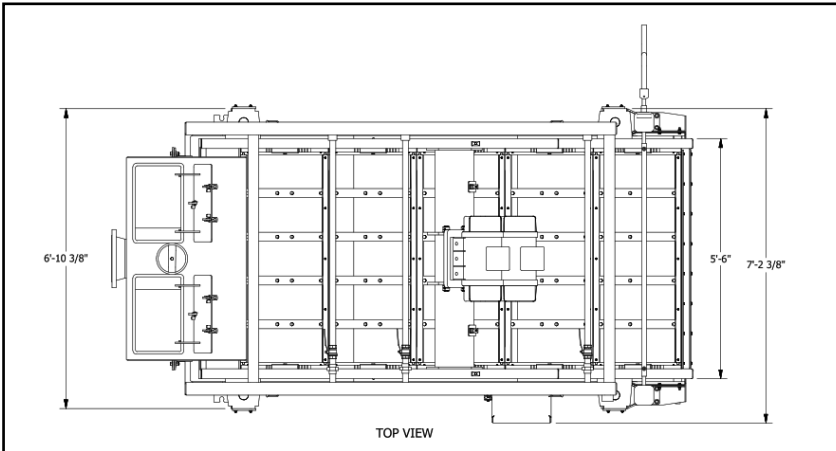
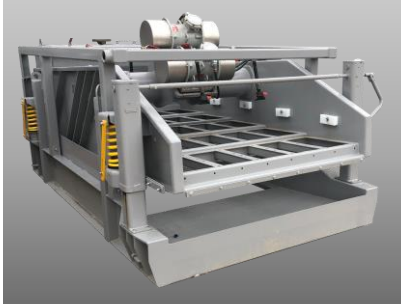

Specifications

• Length	159.625 in. 4054.5(mm)
• Width	87in. 2209.8(mm)
• Height	56 in. 1422.4(mm)
• Weight	7,500 lbs. 3402 (Kg)

Motor Specifications

- (2) Vimar DDP600-6
2.3HP 1175 RPM 460V 60 Hz
6.4 maximum G-Force
- (2) Martin MVX18-11100
2.5HP 1800 RPM 480V 60 Hz
6.4 maximum G-Force
- 20 Amp Service

Class I Groups C & D, Class II Groups E, F & G, T4

Equipment Capacity

Approximately 50 ft² of screening area

Deck angle adjustable to suit flow needs

Unit available with Desanding and Desilting options as well

DELineator 5000 LDS

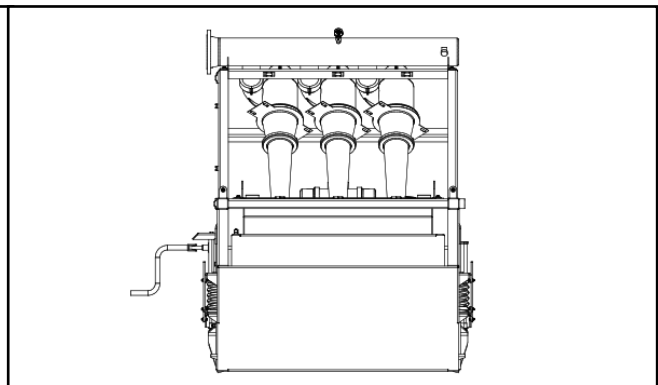
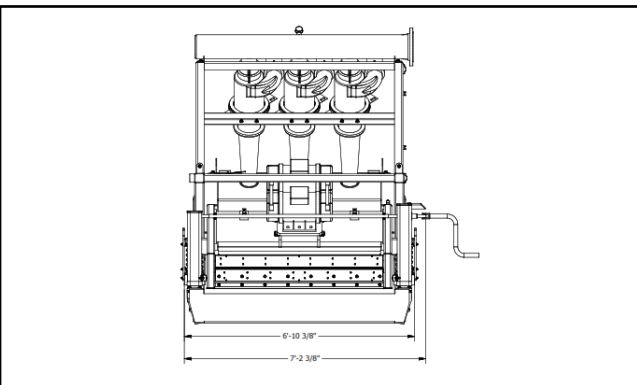
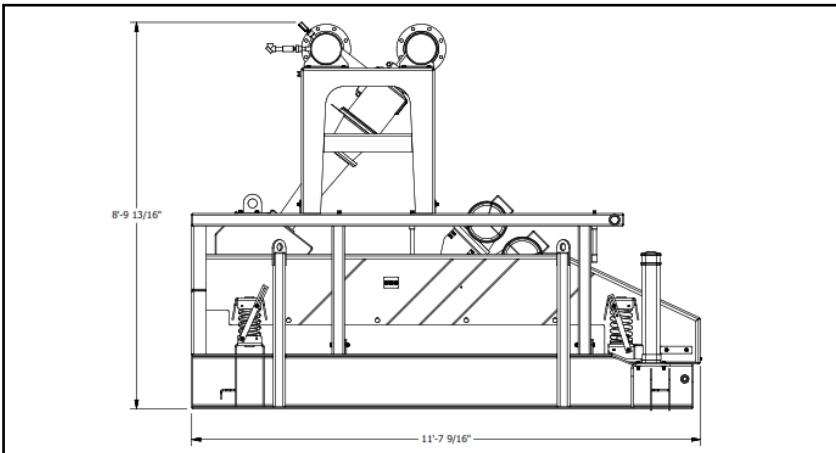
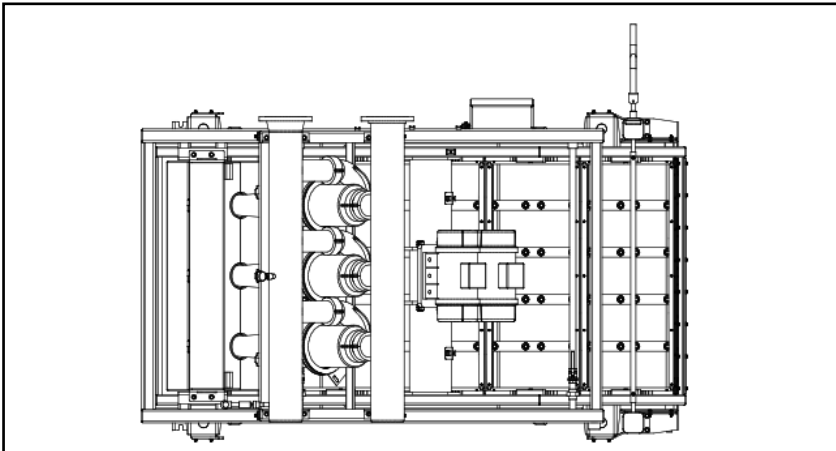
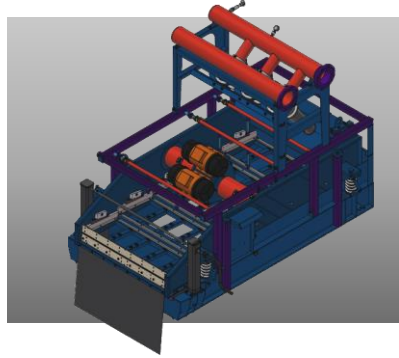
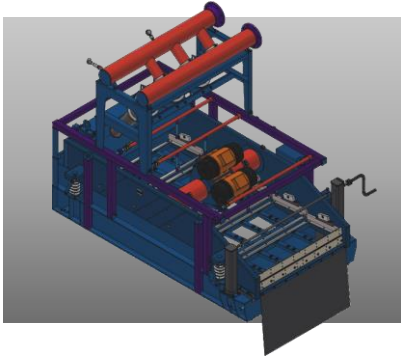

Specifications

• Length	140 in. 3556(mm)
• Width	87 in. 2209.8(mm)
• Height	106 in. 2692.4(mm)
• Weight	8,000 lbs. 3628.74 (kg)

Motor Specifications

- (2) Vimar DDP600-6
2.3HP 1175 RPM 460V 60 Hz
6.4 maximum G-Force
- (2) Martin MVX18-11100
2.5HP 1800 RPM 480V 60 Hz
6.4 maximum G-Force
- 20 Amp Service

Class I Groups C & D, Class II Groups E, F & G, T4

Equipment Capacity

Approximately 50 ft² of screening area

Deck angle adjustable to suit flow needs

(3) Krebs Cyclone 10" G-Max Cones for fines removal